

OWNER'S MANUAL

500EV-1

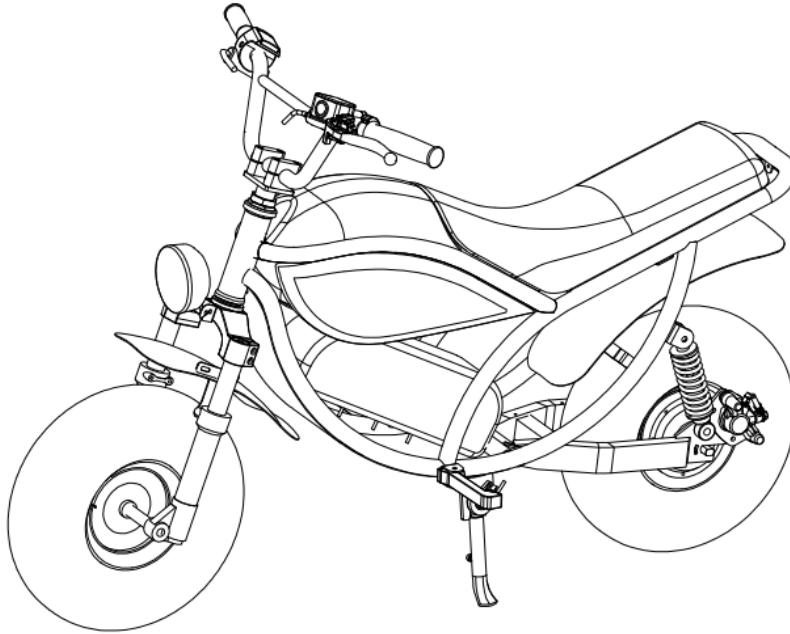

RECOMMENDED AGE 12+

Provincial / Municipal governments have different regulations pertaining to owning and operating an off-road vehicle, learn the regulations in your area.

The driver must wear bike helmet with safety certification. Please read this owner's manual carefully before use! And use it under the guidance of professionals.

Preface

Dear customers:

Thank you for choosing off-road mini electric bike (hereinafter referred to as mini bike). This owner's manual will provide the driver with information about safe operation instructions, maintenance and service. Please read this statement carefully before you use this product.

If you have actually used our products, you will be deemed to have understood and approved all contents of this statement.

When you use this product, you must follow the instructions of the owner's manual and comply with national laws and local traffic regulations.

The user shall be responsible for the adverse consequences arising from the following circumstances.

- Violation of laws and regulations
- Improper use
- Disassemble and change the original configuration without authorization
- Illegal operation

Fully understanding this manual, complying with all the instructions and understanding the necessary knowledge in this manual will provide you with a happy, interesting and safe driving. Proper use, storage and maintenance can reduce vehicle failures, which can ensure your driving safety, maintain the best performance of the vehicle and extend its service life. Be sure to read this manual carefully before driving. For the driving and maintenance questions about this mini bike, please contact your dealer or manufacturer.

Instructions

The recommended age for operating this mini bike is 12 years old and above. Even if a child reaches the minimum recommended age, children under 16 still need adult supervision. The mini bike is not a toy and there is danger when driving.

Children differ in skills, physical strength and judgment. Some children may not be able to operate the mini bike safely. Parents should only allow their children to continue using the mini bike if they are sure that they have the ability to operate it in a safe way.

The mini bike is not a toy. It is dangerous when driving. Driving a mini bike is different from driving other vehicles. Even in daily driving, if you do not slow down in time when turning or driving on obstacle roads, it may cause collision or rollover.

Read this user or operator manual!

- ① Owners and all drivers of this mini bike should carefully read this manual from beginning to end.
- ② No one is allowed to drive this mini bike without reading and understanding the owner's manual.
- ③ This manual is an integral part of the mini bike. Please always carry it with you. When the mini bike is sold, this manual shall be delivered together.

This manual emphasizes particularly important information. Please note the following:

 This is a warning sign, which means pay attention! Stay alert! It's about your safety.

To emphasize important safety information, words with a "WARNING" sign have a special definition:

 It indicates a potential hazard that could result in SEVERE INJURY or DEATH to the driver/bystander and the maintenance and inspection personnel of mini bike.

To emphasize important safety information, words with a "Attention" sign have a special definition:

Attention: It indicates that special pre Attentions must be taken to avoid damage to the mini bike.

To emphasize important safety information, words with a "ATTENTION" sign have a special definition:

ATTENTION: It indicates critical information to make maintenance easier or more clearly understood.

ATTENTION: The product information collected and published in this manual is the latest at the time of publication. However, due to the continuous improvement of the product and other changes, there may be some inconsistencies between your mini bike and this manual. We reserve the right to change the product at any time without notice, and have no obligation to make the same or similar changes to the vehicles previously manufactured or sold.

Table of Contents

I. Precautions for users	4
II. Description of components and parts	7
III. Removal/installation of battery	8
IV. Specifications	8
V. Safety regulations	9
VI. Safety tips for battery charging	10
VII. Maintenance	11
VIII. Vehicle identification number	13
IX. Common faults and troubleshooting methods	13
X. Electrical schematic diagram	15

I. Precautions for users

1. Safety warning



Warning: There are potential risks and pre Attentions for mini bikes.

Many of the friends who like to ride mini bikes are not beginners. Of course, the veteran may also lose control or accidentally fall into a dangerous situation (for example, fall or ride to dangerous road conditions). Adults have the responsibility to take care of children. They must realize that if such a thing happens, it may cause serious injury or death. Even if safety measures and other preAttentions have been taken, it is also necessary to clearly understand the risks and common sense of safe use during riding.



Warning: Children must drive the mini bike under the supervision of their parents or adults.

When riding a mini bike, there may be dangers that you can't predict, so parents need to assume the responsibility of child custody. When choosing a mini bike, you should choose a product that is suitable for your child's age. Different products are suitable for children of different ages. Therefore, make sure that your are familiar with the performance of the mini bike products you choose and it is suitable for your children's current age before purchasing this series of products. In order to eliminate its harmfulness, please read this owner's manual carefully before riding.

The recommended age for this product is over 12 years old. No rider should try to ride a bike that he cannot handle. Parents should choose this product according to their children's age and ability. At the same time, riders should have the ability to ride and comply with safety rules.

Please keep this product away from children, and remember that it is only allowed for qualified people to ride. At least, children should ride this mini bike safely under adult supervision.

Riders can ride only when they have psychological or physical conditions. Otherwise, it will cause injury. The rider must have a strong body and good mental ability, and understand and follow the safety instructions and understand the risks of using the mini bike. Failure to follow the safety warnings will be deemed as improper use and any safety accident will be borne by the rider or his guardian. The rider's weight shall not exceed the weight limit of 150 pounds (68 kilograms). The weight of a rider does not reflect the age of the rider. Proper weight matching can maintain good handling of off-road vehicles.



Warning: Before riding the mini bike, you must understand the common safety sense and the above serious risks to reduce the potential risks.

2. Check before riding

Attention: It is important to check the condition of the vehicle before driving each time. The pre-driving checklist will help you reduce the chance of injury or trouble caused by mechanical problems and ensure that your bike is in good working condition before driving each time.

Inspect ion content	Direction handle	Brake	Tires	Headlight	Speed control handle	All fastener	Battery
Inspect ion focus	- Stable -Unrestricted movement	- Correct liquid level - Check the hose for leakage - Check whether the brake pads are worn	- Appropriate tire pressure Whether the outer tire is worn Whether the rubber has cracks	- Turn on the light by proper operation	- The handle will return to the initial state after release, without jamming during startup	- Tighten all bolts and nuts - No abnormal noise when the vehicle is running	- Check whether the power is sufficient

3. Riding conditions

1. Attention: The mini bike can only be used on non-road or off-road sites. Pay attention to and abide by the local laws or regulations, which may affect the riding regulations. Keep safe under all circumstances, keep away from cars and large vehicles, and use them only where allowed.

2. Don't take chances. Ride outdoors in a suitable environment. Beginners should pay special attention not to compete with others and not imitate others' difficult actions, which will be very dangerous!

3. The maximum speed of the normal power supply of the vehicle. The conditions that may affect the speed are as follows: the weight of the rider, the road slope, the tire pressure and the battery charging level. Avoid excessive speed when riding downhill to ensure safe riding.

4. Always keep your hands on the handlebars during riding. Do not touch the brake at will during normal riding, which may make the motor very hot and reduce the service life of the motor.

5.Attention: During cycling, always pay attention to potential obstacles, avoid gaps that can block your wheels, and avoid emergency turns that may cause the bike to lose control. Be careful to avoid pedestrians, skaters, skateboards, bicycles, children or animals that can enter your path, and respect the rights and property of others.

6. Attention: The mini bike can only be ridden by one person. It can't be ridden at night or with limited visibility. It is forbidden to ride without following the using steps or ride near the swimming pool.

7. Attention: Keep your hands, feet, hair, body, clothes, etc. away from moving parts of the bike (such as wheels, motor and other moving parts).

8. Attention: Do not use headphones or mobile phones while riding.

4. The correct outfit of the rider

Helmets, eye protective gear and protective clothing

A bike helmet (1) with safety certification must be worn. The helmet helps prevent serious head injury in the event of an accident. Helmet is the most important safety equipment that you must wear. Consult your bike dealer for the appropriate helmet size and model.

Always wear eye protective gear, such as a face shield or goggles (2), when driving a mini bike .

When driving a mini bike, any of the following may hit the eyes: dust, sticks, rocks, debris, bugs, etc.

Therefore, it is necessary to properly wear eye protective gear while driving.

Wear protective clothing: long-sleeved shirt (3), gloves (4), trousers (5), ankle boots (6).

When driving a mini bike, the driver's body is exposed. Wearing protective clothing can help protect the operator from injury.

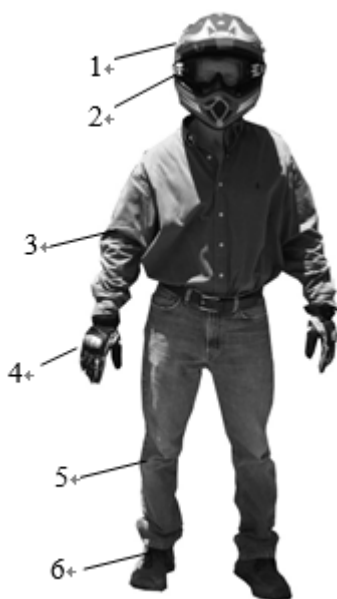

Warning

It is dangerous to drive a mini bike without wearing a helmet, eye protective gear and protective clothing correctly.

Driving a mini bike without a helmet will increase the probability of severe head injury or death in an accident.

Driving a mini bike without eye protective gear devices (such as face shield or goggles) may cause severe injury in the event of an accident.

Driving a mini bike without protective clothing (ankle boots, trousers, gloves, long sleeved shirt) may cause severe injury to the driver.

When driving a mini bike, you must wear a helmet, goggles, long sleeved shirt, ankle boots and gloves.

5. Start

The controller has the function of anti-runaway protection:

(1) When the stand is in the down state, the side stand must be lifted after pressing the start switch for 2 seconds. At this time, the motor will run by turning the acceleration handle;

(2) When the stand is in the raised state, press the start switch for 2 seconds, then the bike enters the P-gear mode. You must apply the brake handle and quickly release it. At this time, turn the acceleration handle, and the motor will run;

Supplementary notes:

At the end of the ride or when the rider is sitting on the vehicle and talking with others, he/she should put down the side stand to avoid mistakenly rotating the acceleration handle to make the motor run, which will cause the vehicle to rush forward accidentally and cause accidents.

When the rider stops the vehicle and does not put down the side stand, and does not act on the vehicle within one minute, the vehicle will automatically enter the P position. If you need to ride the vehicle again, please refer to (2).

If the vehicle is stationary and the rider does not operate within 10 minutes, the vehicle will automatically shut down. If the rider wants to continue riding, just press the start switch for 2 seconds.

①. Stand down state

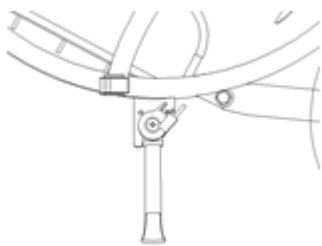

②. Stand raised status

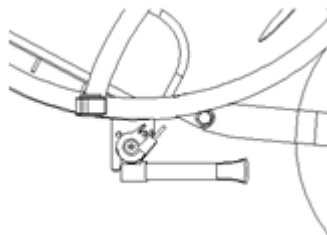

③. Meter

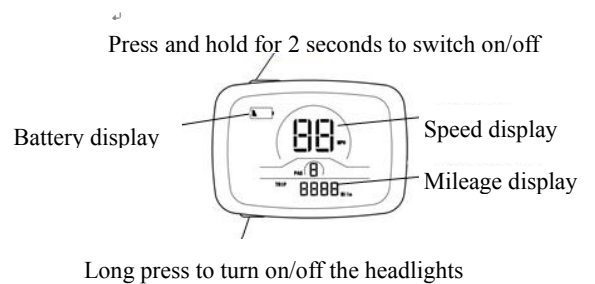

II. Description of components and parts

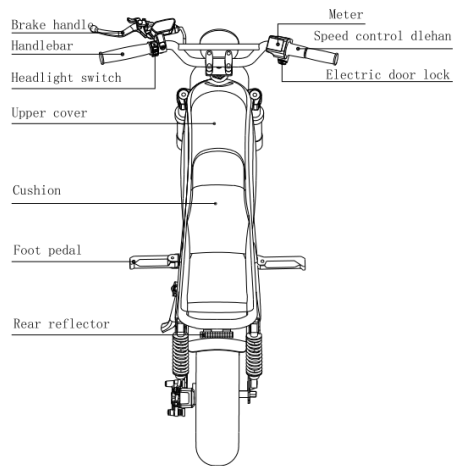
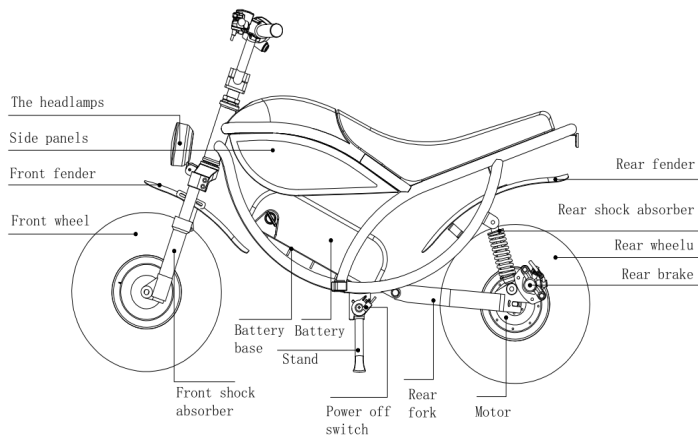

III. Removal/installation of battery

①. Insert the key

②. Turn the key to open the lock

③ Gently push the battery upwards to separate from the battery base

④ Take out the battery from the side of the bike

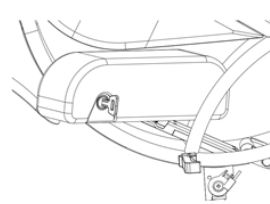
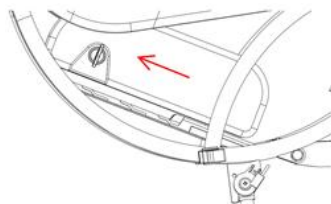
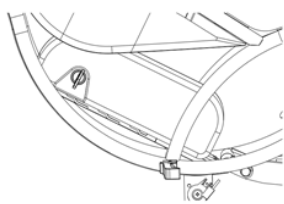
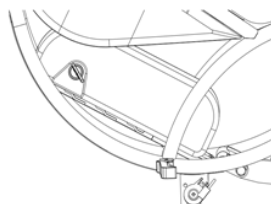

The battery installation can be carried out in reverse order.

IV. Specifications

Specifications of 500EV-1 electric bike

Item	Specifications
Overall dimension (length × width × height) (mm)	1285×615×815
Wheelbase (mm)	915
Minimum ground clearance (mm)	170
Curb mass of the whole vehicle (kg)	35
Rated load capacity (kg)	68
Brake type (front/rear)	None/hydraulic disc brake
Brake control mode (front/rear)	None/handbrake
Rim type (front/rear)	Iron hub/motor hub
Tire specification (front/rear)	110/100-6 / 110/100-6
Tyre pressure (front/rear)/(P.S.I)	10P.S.I/10P.S.I
Battery	48VDC, 8Ah
Charger	100-240VAC~50/60Hz
Controller	48V, 500W
Motor model	DC brushless hub motor
Rated voltage (V)	48VDC
Output (rated) power	500W

V. Safety regulations

1. Attention: Before use, check whether personal protective measures are in place.
2. Attention: Check whether the brake function is normal and whether the tire pressure meets the

requirements.

3. Please grasp the handrail when the vehicle starts or runs.
4. Caution: Please avoid sudden starting, steering in place, sudden braking and other dangerous operations.
5. Caution: Be careful when starting or accelerating. Sudden acceleration will make the wheels spin and slip, causing the vehicle to slip laterally.
6. When riding, please pay attention to the surrounding conditions and drive safely.
7. Please ride the vehicle in a straight line when going up and down the slope.
8. Be careful when ride on uneven roads.
9. Attention: When changing the riding direction, be sure to confirm the situation around.
10. Be sure to slow down when turning.
11. When going downhill, use the brake to slow down and drive the vehicle.
12. Caution: Be careful not to speed up when going downhill. A sudden braking or direction change will cause the vehicle to lose control.
13. Be sure to pay attention to the back environment when the vehicle moves backward.
- 14 Do not drive the vehicle overweight or drive it to climb the over-limit slope, otherwise the motor and electric control system will be damaged and the service life of the whole vehicle will be shortened.
15. Attention: The mini bike should be kept in compliance with the manufacturer's specifications. Only parts authorized by the manufacturer should be used for replacement, and the original design and configuration of the manufacturer should not be changed at will.

VI. Safety tips for battery charging

1. The charger provided by the mini bike should be checked regularly to find the damage of wires, plugs, shells and other parts in advance. If the charger is damaged, it cannot be charged directly. It is necessary to wait until the charger has been repaired or replaced with a new charger to ensure the normal service life of the battery.
2. If your charger needs to be replaced, please contact your local dealer in time, and we will provide you with another charger. If the original charger is not a quality problem, we will charge an appropriate fee.
3. Attention: The battery charging process can only be carried out by adults.
4. Attention: The charger should not be placed close to flammable materials when working.
5. When not in use, you must unplug the charger power terminal and disconnect the on-board charging port.

6. The charging process should be carried out in a safe, ventilated, dust-free and rain-free environment.
7. ⚠ Attention: In any case, it is forbidden to wipe and clean your mini bike with wet cloth before disconnecting the charger.
8. Always charge the vehicle when you use it, and keep the battery in full charge.
9. The charging time shall be determined according to the journey, controlled within 9 hours, and not for a long time.
10. If the battery is laid aside for a long time, it is recommended to unplug the power cord connecting the battery and the controller. It needs to be fully charged and recharge once a month.
11. There is a certain temperature rise when the charger works. Please pay attention to heat dissipation. The charging time is generally 6-8 hours (the actual charging time depends on the degree of power release). The power indicator is red when charging, and green when the battery is fully charged.
12. Charger is a relatively precise electronic equipment, so pay attention to anti-vibration, rain and moisture protection during use.
13. Attention: Avoid exposure to the sun during charging. If the ambient temperature is too high, the internal components of the charger will be overloaded, resulting in accelerated aging of components.
14. Attention: When there is only one grid of power left, it indicates that the battery power is nearly exhausted, and the battery must be charged as soon as possible.

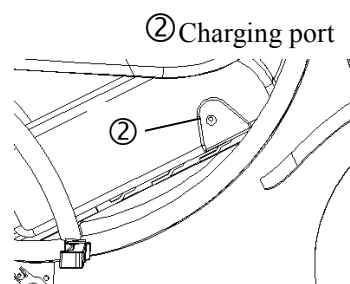
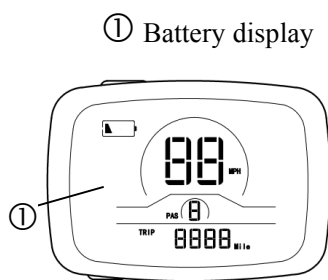

VII. Maintenance

1. Motor Maintenance

- 1.1 ⚠ Attention: When checking and maintaining the motor, the power must be cut off to avoid accidents.

1.2 In order to ensure the normal operation of the vehicle, the long-time full-open switch operation shall be avoided.

1.3 It is not necessary for users to maintain the internal parts of the motor during use. They only need to check the status of the fasteners installed on the rear fork of the electric hub. If any nuts are loose, they should tighten the nuts in time or ask professionals to check and handle.

1.4 Attention: In rainy days, if the water depth on the road exceeds the center of the electric hub, it may cause water seepage of the motor and cause motor failure.

1.5 The electric hub shall not be subjected to severe impact and shall not be started under blocked condition. When the mini bike cannot be started due to obstruction, do not start it repeatedly. Start it after removing the obstruction.

The contents of regular maintenance are as follows:

- ① Clean the dirt and oil sludge on the outside of the motor wheel axle in time;
- ② Check and maintain the motor wiring terminals, and check whether the wiring is loose and tidy;
- ③ Check the bolts and nuts of each fixed part to ensure that the connection point is fixed effectively.

2.Controller Maintenance

2.1 Attention: The controller is a highly integrated electronic product, which is sensitive to static electricity and temperature. Before each maintenance and operation of functional components and controller, remember to cut off the power to avoid accident and loss. During use, pay attention to ventilation and heat dissipation around the controller, and overload operation is prohibited.

2.2 The contents of regular maintenance are as follows:

- ① Regularly clean the dust on the surface of the controller to facilitate heat dissipation;
- ② Check the controller plug regularly to prevent the controller failure caused by false connection;
- ③ If the controller is wet with water, clean the controller lead and plug with alcohol in time to avoid oxidation and corrosion.

3.Tire Maintenance

3.1 The tire pressure will decrease gradually. Check the pressure of the tires at regular intervals and inflate the tires properly.

3.2 Ensure that the two tires are inflated correctly, do not inflate excessively, and try to keep the pressure of the two tires the same. The default tire pressure of both tires is 10PSi.

3.3 Maintain proper air pressure during use to ensure the best state of riding and eliminate hidden dangers.

4. Storage

Attention: Avoid storing the mini bike under direct sunlight. High temperature may damage the function of

battery and mini bike. Avoid storing in wet conditions. When the mini bike is not used for a long time, it is necessary to pull out the connector between the battery and the controller to avoid battery power loss. You should test the battery at least once a month to ensure that the battery remains fully charged. Avoid leaving the mini bike [and battery] idle for a long time, as this may cause battery failure. In winter, due to low temperature or harsh environment, the battery may power off faster, and the storage capacity of lithium battery will be reduced, which will shorten the battery service life or cause other mechanical problems. Please store the mini bike indoors in a cool and dry place away from fire.

5. Cleaning

Attention: Before cleaning, make sure that the mini bike is switched off. Unplug the charging cable and cover the charging port. During cleaning, be careful to prevent water and moisture from entering the port. Use a dry or wet cloth to clean the cable. Do not immerse the mini bike in water, otherwise it will cause permanent damage.

6. Battery recycling

Attention: Proper recycling of batteries helps to protect the environment from garbage and harmful pollution. Do not throw batteries into the trash can. Please be responsible for recycling batteries. Please consult the relevant local authorities for guidance on safe handling of batteries and components.

VIII. Vehicle identification number

1. When you need parts, service center help or register your mini bike, you need the vehicle identification number and motor code.
2. The frame number is located on the frame.
3. The motor code is located on the motor.

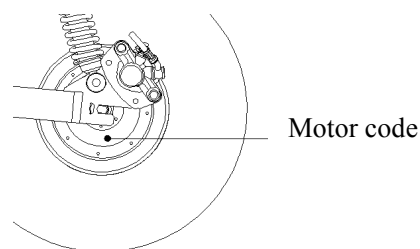
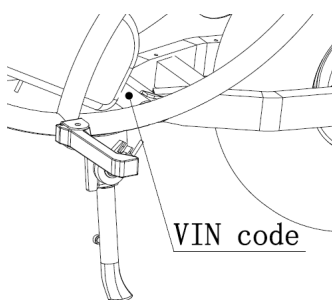

IX. Common faults and troubleshooting methods

In case of failure during use, please try to repair it according to the troubleshooting method in the following table. If it doesn't work, please contact the company's maintenance station. Do not disassemble

and repair by yourself to avoid damaging the machine parts.

Fault	Cause analysis	Solution
Motor does not work	Rotation acceleration handle motor does not work	First of all, read the owner’s manual carefully. After starting the power switch, you must lift the stand (side stand protection) and hold the brake handle (no sequence) , then the motor starts to work.
	Loose battery wiring, motor and controller connectors	Check whether the connectors are connected normally and whether the connectors are firmly inserted.
Power supply does not work	Loose connector	Check whether the controller connection plug-in is loose/whether the power switch plug-in is loose/whether the battery is connected normally or loose.
	Charging not work	Check the indicator light of the charger: when the charger is plugged in, if the indicator light shows red, indicating normal charging, and if the indicator light shows green, indicating that the battery is fully charged or the connection with the charging port is abnormal. Please check whether the connection between the controller (charger and battery) is normal. After confirming that the connection is normal, please replace with a new charger.
Insufficient endurance	Rider's weight	Exceeded the maximum weight limit of 150 pounds
	The battery is not fully charged	To charge the battery, the indicator light needs to change from red to green.
	Old/damaged battery	Replace the battery (according to relevant regulations).
	Improper inflation of tires	Tires will lose some pressure over time. Check the tires regularly and inflate them correctly.
Intermittent operation	Connector connection is loose	1. Check the controller and surrounding wires to ensure that the connectors are firmly connected. 2. Replace the acceleration handle.
Other faults	1. When you cannot eliminate the fault by yourself under the above guidance; 2. When the motor hub, controller, charger and battery pack are damaged internally	In case of the above conditions, please contact the supplier or maintenance station. Do not open the above parts without authorization.

Attached Table 1: Fault Code Definition Table

Fault code	Fault name	Troubleshooting
Error05	Brake failure	Whether the brake is in position; Replace the brake handle
Error06	Battery undervoltage	Battery requires charging
Error07	Motor fault	Check whether the power line is loose.
Error08	Handle failure	Whether the handle is returned; Check the handle link. If it is normal, replace the handle.
Error09	Controller failure	Check the controller hall connection.
Error10	Communication reception failure	Check whether the instrument cable is connected properly.
Error11	Communication transmission failure	Check whether the instrument cable is connected properly.

Notes: When you press and hold the start key for 2 seconds, it enters the power-on state, the meter displays E005, and the meter display will return to normal when you lift the side stand. If it still display E005 when the side stand is lifted, please check whether the switch at the hand brake switch is normal. If it is abnormal, please replace it in time.

X. Electrical schematic diagram

