

USER'S MANUAL



Important Notice:

Please read this user manual carefully before use.
Use the vehicle under the guidance of professionals.
Restricted for use on non-road or non-road sites.

PAEFACE

Thank you for choosing Kandi Golf Carts.

1. This user's manual will provide the driver with information about safe operation instructions, maintenance and service.
2. Fully understanding this manual, complying with all the instructions and understanding the necessary knowledge in this manual will provide you with a happy, interesting and safe driving.
3. For the driving and maintenance questions about this Golf Carts, please contact your dealer or manufacturer.

User Notice!

Minors under the age of 16 are not allowed to drive this Golf Carts! Not all people have the strength, appropriate age, skill and judgment to drive this Golf Carts.

Golf Carts are not toys, and they are dangerous when driving. Golf Carts are different from other vehicles, such as motorcycles and cars. Even during everyday driving, cornering and driving over obstacles can result in a crash or rollover.

Read this user or operator manual!

1. Owners and all drivers of Golf Carts should carefully read this manual from beginning to end.
2. No one is allowed to drive this Golf Carts without reading and understanding the user's manual.
3. This manual is an integral part of the Golf Carts. Please always carry it with you. when the utility vehicle is sold, this manual shall be delivered together.

This manual emphasizes particularly important information. Please note the following:



This is a warning sign, meaning attention! Stay vigilant! Involving your safety.

To emphasize important safety information, words with a "WARNING" sign have a special definition:

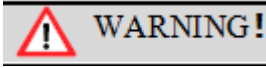

It indicates a potential hazard that could result in SEVERE INJURY or DEATH to the driver/bystander and the maintenance and inspection personnel of Golf Carts.

To emphasize important safety information, words with a "ATTENTION" sign have a special definition:

ATTENTION! It indicates critical information to make maintenance easier or more clearly understood.





The product information collected and published in this manual is the latest at the time of publication. However, due to the continuous improvement of the product and other changes, there may be some inconsistencies between your Golf Carts and this manual. We reserve the right to change the product at any time without notice, and have no obligation to make the same or similar changes to the vehicles previously manufactured or sold.

list

Important safety labels	5
Warning labels on the car	5
Safety	7
Description of components position	8
Power display	9
One key start switch	8
Headlamp switch	8
Telescopic rod switch	8
Shift gears switch	8
Horn button.....	9
Charging socket.....	9
Front storage box.....	10
Front windshield open	10
Steering wheel adjustment.....	11
Vehicle retraction function	12
Check before driving	18
Driving	Error! Bookmark not defined.
Parameter	20
Vehicle nameplate	21

Important Safety Labels

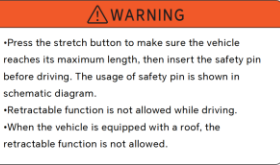
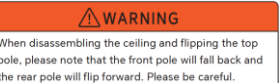
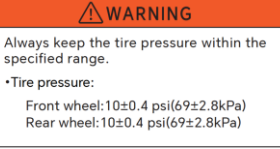
Warning label

 <p>WARNING</p> <p>Incorrect use can cause the Severe INJURY or DEATH. Please read and fully understand this instruction before operating your golf cart.</p> <ul style="list-style-type: none"> • Fasten seat belts. • Wear proper helmets and protective gear. • Do not operate the vehicle after consuming alcohol or drugs. • Do not overload. (Max load: 180KG) • When driving, please keep your body inside the vehicle. • When the vehicle is moving, please sit still and hold on tightly. • Drive carefully to avoid losing control and turning over. • Use vehicle properly to prevent injury, avoid sudden movements, sidslip, skid, and tail flick. • Slow down before entering a turn. • Always Drive slowly on or under a slope. • Make sure to pay attention to and plan the road ahead, you may feel the vehicle tilted or rolling to reduce the risk of injury. • Not allowed on public roads or sidewalks (unless designated as off-road vehicular access)-possible collision with cars and trucks. • Please obey the local traffic regulations and be courteous to pedestrians. <p>Locate and Read Owner's Manual Follow All Instructions and Warnings (Please refer to Reference to Other Sources of Safety Information)</p> <p>NO ALCOHOL OR DRUGS NO PASSENGERS NO PUBLIC ROADS OR SIDEWALKS NO EXCESSIVE SPEEDS NO OVERLOADING</p>	<p style="text-align: center;">Warning</p> <p>Improper use of Golf Carts may cause serious personal injury or death:</p> <ul style="list-style-type: none"> • Before driving, please read the 'User Manual'. • Please wear protective gear while driving. • Do not exceed the speed limit. • Off road use only. • Do not drive after drinking or taking medicine. • Do not overload driving (maximum load capacity of 180Kg).
 <p>WARNING</p> <p>UNDER 16</p> <p>Operating this UTV if you are under the age of 16 increases your chance of severe injury or death. NEVER operate this UTV if you are under age 16.</p>	<p style="text-align: center;">Warning</p> <p>Operating this car if you are under the age of 16 increases your chance of severe injury or death. Never operate this car if you are under the age of 16</p>
 <p>WARNING</p> <ul style="list-style-type: none"> • Press the stretch button to make sure the vehicle reaches its maximum length, then insert the safety pin before driving. The usage of safety pin is shown in schematic diagram. • Retractable function is not allowed while driving. • When the vehicle is equipped with a roof, the retractable function is not allowed. 	<p style="text-align: center;">Warning</p> <p>Before driving, please ensure that the body push rod has been pushed to its maximum value and the limit bolt has been inserted in place. Do not touch the push rod control button while driving.</p>
 <p>WARNING</p> <p>When disassembling the ceiling and flipping the top pole, please note that the front pole will fall back and the rear pole will flip forward. Please be careful.</p>	<p style="text-align: center;">Warning</p> <p>Fasten the seat belt before driving or seating!</p>
 <p>WARNING</p> <p>Always keep the tire pressure within the specified range.</p> <ul style="list-style-type: none"> • Tire pressure: Front wheel: 10±0.4 psi (69±2.8kPa) Rear wheel: 10±0.4 psi (69±2.8kPa) 	<p style="text-align: center;">Warning</p> <p>Improper tire pressure or overloading can cause loss of control. Loss of control can result in severe injury or death. Working tire pressure: set when the tire is cold.</p> <ul style="list-style-type: none"> • Rated tire pressure: 10psi ± 0.4 (69 ± 2.8kPa) • Never set the tire pressure below the minimum value. • The tire may dislodge the rim.
 <p>WARNING</p> <p>Release the parking brake before driving!</p>	<p style="text-align: center;">Warning</p> <p>Release the parking brake before driving !</p>

 **WARNING**

- Before charging, make sure the switch is locked in off and the brake is on.
- Charge the battery after use in time.
- Stop charging period when the charging indication light becomes green.
- Charge should not exceed 10 hours.
- Charge the battery at least once per month.
- Charge only with the Charger provided.

Warning

Ensure that the vehicle is turned off before charging.

- Please charge in a timely manner after use.
- Please stop charging after the indicator light turns green.
- Do not charge for more than ten hours.
- Ensure that the vehicle is turned off before charging.
- Please ensure to charge at least once a month.
- Only use the charger provided by our company for charging

Safety

1. Before starting the vehicle for the first time, you must read and understand the user's manual and relevant warning labels.
2. Do not modify this Golf Cart in any way that may make the vehicle unsafe or violate the law.
3. Minors under the age of 16 are not allowed to drive this Golf Cart.
4. The driver must wear a motorcycle helmet with safety certification, goggles, gloves, a long-sleeve shirt, and long pants before driving this Golf Cart.
5. This Golf Cart is designed for one driver and one passenger, and it is not allowed to exceed the capacity.
6. Seat belts must be worn correctly, and ensure that the driver and the passenger fasten their seat belts before starting the Golf Cart.
7. For off-road use only.
8. Pay attention to changes in terrain conditions when driving Golf Carts. Drive slowly on unfamiliar terrain and be vigilant; otherwise, accidents may occur.
9. Do not take drugs or alcohol before or during the operation of the Golf Cart.
10. Please read the pre-check procedures in this manual carefully before driving.
11. Keep hands, arms, legs, and feet inside the electric utility vehicle at all times.
12. Do not drive a Golf Cart in water deeper than 20 cm (8 inches). Do not drive in fast-flowing water. Water can affect the braking performance of Golf Carts. After passing through water, check whether the braking performance is normal.

Description of components position



Power display

Engine start stop

Headlamp switch

Telescopic rod switch

1、 Power Display

The battery level display is located on the dashboard near the steering wheel.

When the battery level is less than 20%, please charge it promptly.

2、 Engine Start-Stop

Press this switch to power on the entire vehicle. Press the same button again to power off the vehicle; in this state, the vehicle cannot run.

3、 Headlamp Switch

The switch is located below the cup holder.

- ①、 Press the upper end of the switch to turn on the headlights.
- ②、 Press the lower end of the switch to turn off the headlights.

4、 Telescopic Rod Switch

The switch is located below the cup holder.

- ①、 Open the protective cover, press the upper end of the switch to extend the telescopic rod..
- ②、 Press the lower end of the switch to retract the telescopic rod.



5、 Shift Gears Switch

This switch is located on the protruding platform below the seat.

①、 The switch in the middle position is in neutral ("N"), and when parking, the gear switch should be in the middle position.

②、 Press the front end of the switch ("D") to engage forward gear, putting the vehicle in a forward state.

③、 Press the rear end of the switch ("R") to engage reverse gear, putting the vehicle in a reverse state.



6、 Horn Button

This button is located inside the steering wheel logo; press it to sound the electric horn.



7、 Charging Socket

When charging is needed, move the locking tab of the charging socket cover to expose the charging socket for use.

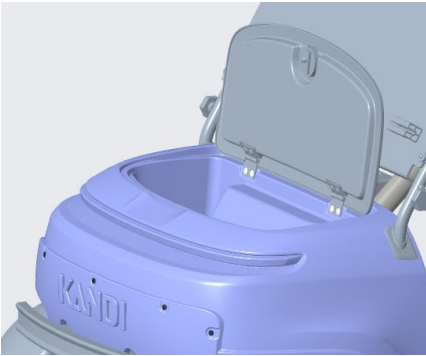

8、 Front Storage Box

At the front of the car, there is a storage box. Insert the built-in key, turn it 90 degrees to the left, pull the pull ring upward, and unlock the storage box cover by moving it towards the rear of the car.

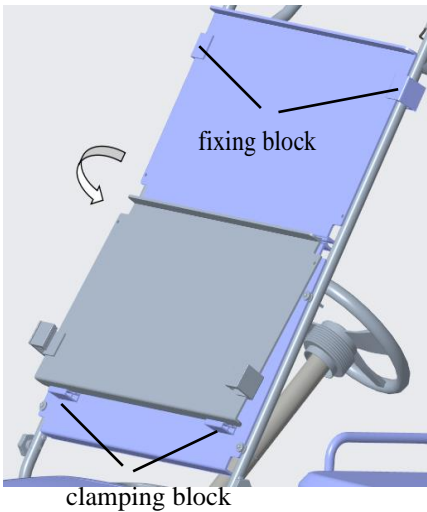

9、 Front Windshield Open

Open the upper fixing block of the front windshield, flip the upper half of the front windshield downwards, and securely clip it into the clamping block.

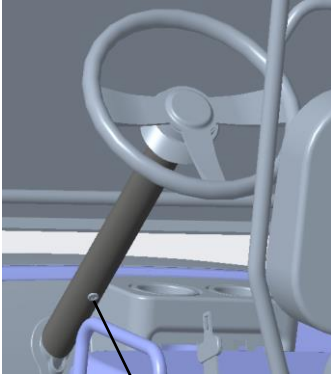

Adjusting nut

10、Steering Wheel Adjustment

Loosen the adjusting nut to adjust the steering wheel up and down. Once in a suitable position, tighten the adjusting nut.

For quick release, remove the adjusting nut, unplug the horn cable quick-release interface, and pull the steering wheel upwards.

Note:

Before driving the golf cart, ensure the steering wheel is in the appropriate position. Never adjust the steering wheel while driving, as it may lead to the danger of losing control of the vehicle.

Vehicle retraction function

一、 Functional description of vehicle shrinkage

1、 Removing the Roof

- ①、 Open the Quick Release.
- ②、 Remove the roof.
- ③、 Place the roof in a suitable location.



2、 Removing the Steering Wheel

- ①、 Tear off the protective cover on the steering wheel pole.
- ②、 Remove the bolts on the steering wheel pole.
- ③、 Unplug the speaker cable using the quick disconnect interface.
- ④、 Pull the steering wheel upwards.
- ⑤、 Place the disassembled steering wheel in a suitable position.



3、 Shrinking the Body

- ①、 Flip the seat forward, rotate the latch handle 90° to the left, lift the latch up 30-40mm, rotate the latch handle 90° to the right, release the latch handle, ensuring that the latch is above the limit, and the seat is restored.
- ②、 Press the down button on the push-pull switch. After retracting in place, return the pushrod switch to the middle position.
- ③、 After retracting in place, return the push rod switch to the middle position.

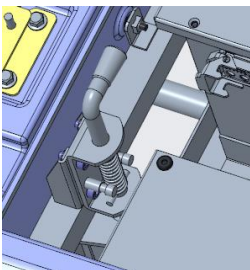

Horn cable quick release interface

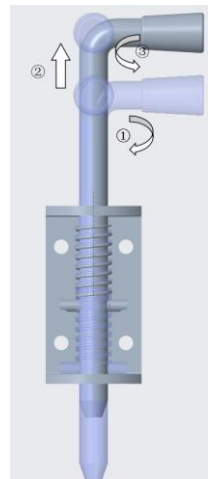

4、 Front Windshield Flip Back Function

- ①、 Remove the hand-twisted floor bolts on both sides.
- ②、 Pull the front windshield component upward along the axis until it can be flipped backward.
- ③、 Flip the front windshield assembly backward.

Attention:

Ensure that the steering wheel is removed before flipping it over.

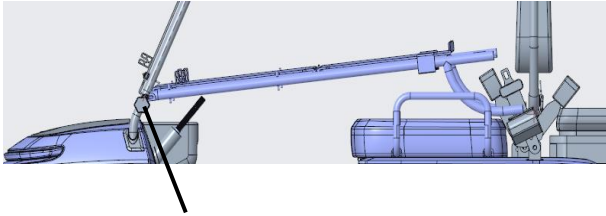

hand twisted bolts

5、 Roof Rear Upright Pole Forward Flipping Function

- ①、 Remove the hand-tightened bolts.
- ②、 Flip the rear upright post of the ceiling forward.

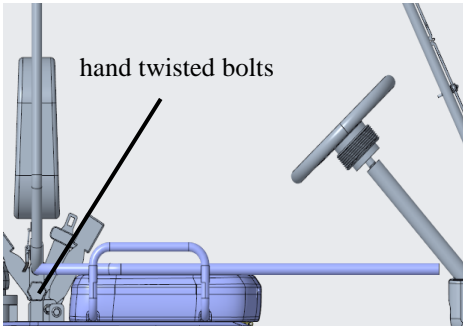

hand twisted bolts

6、 Seat Backrest Flipping

- ①、 Release the quick-release buckle.
- ②、 Pull the seat backrest up until it can be flipped forward.
- ③、 Flip the seat back forward.

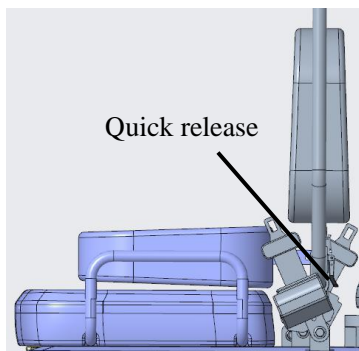

7、 Rear Pedal Folding

- ①、 Release the quick-release buckle.
- ②、 Pull the rear pedal armrest up until it can be flipped forward.
- ③、 Pull the pedal back as a whole until it can be overturned downwards.
- ④、 After flipping it into place, clip the pedal armrest into the plastic clip.

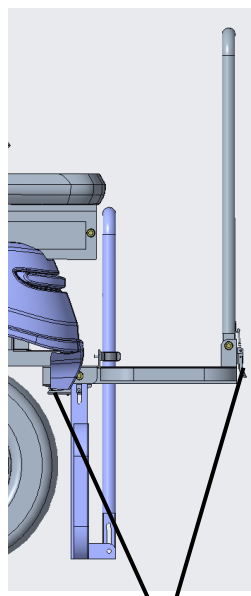

二、 Vehicle extension

1、 Seat Backrest Reset

- ①、 Flip the seat back backward until the square tube can be inserted into the Chesheng steel pipe.
- ②、 Buckle the back and quickly remove it.

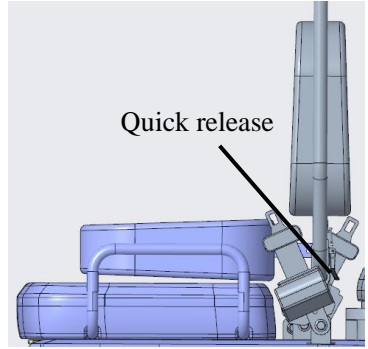

2、 Front Windshield Reset

- ①、 Flip the front windshield component forward.
- ②、 Lock and twist the floor bolt.

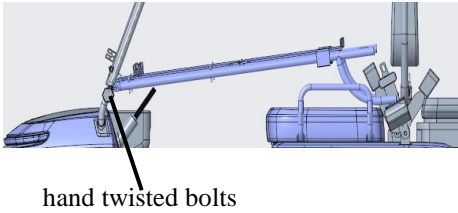

3、 Reset the Upright Post Behind the Ceiling

- ①、 Flip the upright post behind the ceiling backwards;
- ②、 Lock and twist the floor bolt.

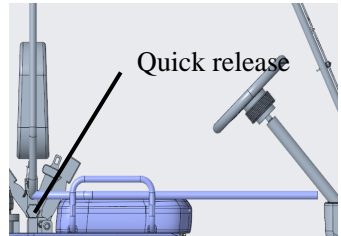

4、 Extended Body

- ①、 Press the up button on the push rod switch.
- ②、 After the extension is in place, return the push rod switch to the middle position.
- ③、 Flip the seat forward, rotate the latch handle 90° to the left, lower the latch to ensure it is inserted into the lower limit hole, and then rotate the latch handle 90° to the right to restore the seat.

Attention:

Before driving the vehicle, ensure that the limit bolt is inserted in place.

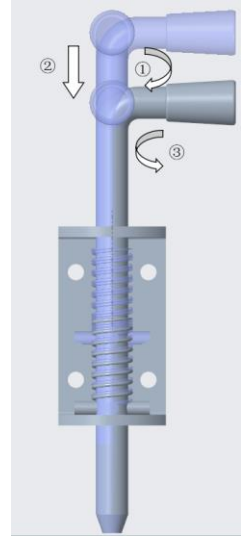

5、 Roof Installation

- ①、 Install the roof in the corresponding position;
- ②、 Buckle the back and quickly remove it.



6、Steering Wheel Installation

- ①、 Install the steering wheel on the steering column, ensuring the correct direction.
- ②、 Connect the horn cable.
- ③ 、 Lock the bolts.
- ④ 、 Install the steering wheel pillar.



Check Before Driving

Checklist

 WARNING!
<ul style="list-style-type: none"> ● It may be dangerous if your Golf Carts is not inspected and maintained. ● Failure to follow the pre-driving inspection procedure may result in the Golf Cart losing control, leading to accidents or vehicle damage. ● Be sure to check and confirm before driving. ● Ensure that the vehicle is in good working condition before driving.

 WARNING!
<ul style="list-style-type: none"> ● Overloading on this golf cart is dangerous. ● Operating a golf cart irresponsibly, including jumping or performing stunts, may be dangerous. ● Please wear your seat belt correctly before driving or riding.

Check Item	Inspection focus
Steering wheel	<ul style="list-style-type: none"> ● Smooth rotation ● No stagnation or looseness
Tire	<ul style="list-style-type: none"> ● Proper tire pressure ● Proper tread depth ● The rubber has no cracks
Braking	<ul style="list-style-type: none"> ● No leakage of hydraulic pipeline. ● No abnormal wear of brake pads. ● The brake pedal should return to its normal position after being stepped down.
Accelerator pedal	Accelerator pedal can return to normal position after stepped down.
Engine start stop	Can start the vehicle normally.
Shifter	Flexible gear switch
Lighting	Headlamps, brake lights can work normally
Power display	Display normally after Starting the vehicle
Power	sufficient power is displayed on the power display
Ordinary situation	Tighten all bolts and nuts

Driving Golf Carts

Start

1. Check and confirm that the vehicle shift switch (①) is in the neutral gear ("N") and the parking brake pedal (②) is engaged.
2. If the vehicle is in a retracted state, extend it for its intended use and insert the retractable limit bolt.
3. If there is a flip, please install each flip component in place;
4. Sit in the driver's seat and press the one button start switch (③) to power on the vehicle;
5. Wait for the battery indicator light to turn on.

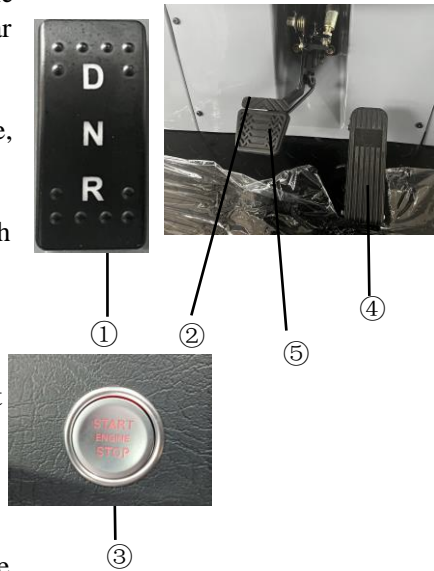

Driving

1. After starting the vehicle, press the upper end of the shift switch (①) to engage the forward gear "D" and release the parking brake by pressing the parking brake pedal.
2. Press the accelerator pedal (④) until the vehicle begins to move.
3. Drive the vehicle slowly until you are fully familiar with its handling characteristics.

Stop

1. Release the accelerator pedal (④) and press the brake pedal (⑤) until the vehicle stops;
2. Press the parking pedal (②);
3. Press the one button start switch (③) to power off the vehicle;

 WARNING !	
●	It is dangerous to drive the Golf Cart at excessive speed ;
●	Over-speed driving will increase the probability of the vehicle losing control, which may cause serious injury or death;
●	Always drive at a speed appropriate to the terrain, visibility, operating conditions, driver skill and driver experience, and be sure to understand the terrain before driving.

Charge

Charging Method and Precautions

1. Open the cover plate of the charging port, align the direction, and connect the power cord plug to the charging socket.
2. Connect the plug at the other end of the power cord to the 110V household power supply.
3. When the charging gun is working, the charging indicator on the PAD will light up. Once the battery is fully charged, the charging gun will stop working, and the charging indicator will go out.
4. After charging, unplug the plug connected to the 110V household power supply. Then, unplug the plug connected to the charging socket on the car. Push the charging port cover back to its original position.

Safety Specification for charging

1. The standard power supply voltage for charging is 110V. The charging socket should be installed by a professional electrician. If installed outdoors, ensure that the charging line and charging gun are moisture-proof and waterproof to prevent power leakage.
2. Use a dedicated line for charging the vehicle, meaning a charging-dedicated line led out from a standard household or unit power socket.
3. The charging time for the vehicle power battery is approximately 8 hours (at 110V). The actual charging duration may vary based on factors such as charging power, remaining power, vehicle service time, ambient temperature, and other conditions.

Battery maintenance

1. The power battery used in this model consists of lithium-ion battery packs connected in series.
2. Charging time: Approximately 8 hours (at 110V)
3. Perform power battery maintenance at least once a month, ensuring it is fully charged.

ATTENTION:

1. **The charging location shall be a place with fire-fighting facilities and good ventilation. At the same time, smoking or storage of power supply is forbidden at the charging place. It is forbidden to charge at a place where inflammables are stacked.**
2. **If abnormal conditions are found at each connection point of the power line, it should be repaired or replaced in time to avoid poor contact and electric spark.**
3. **When charging, children are not allowed to play nearby.**
4. **It is forbidden to use this series of battery packs in series or in parallel with other models or types of battery packs. In of any abnormal situation of the battery pack, the professional technician shall be notified in time for inspection. To avoid danger, it is forbidden to disassemble the lithium battery without authorization.**
5. **If there is smoke, smell or spark during charging, please immediately cut off the power supply and contact the local service station.**

Storage

If the electric utility vehicle is idle for an extended period, proper storage and maintenance are necessary.

1. Thoroughly clean the golf cart, and then apply non-abrasive wax to plastic and painted parts.

Attention:

When cleaning, avoid directly washing the power battery, electrical devices, high and low voltage cables, and their connectors with water.

Maintain normal tire pressure.

If possible, park the electric utility vehicle in a shed or garage to prevent dust and water. If stored outdoors, cover the electric utility vehicle with a waterproof cover.

Disposal of Scrapped Batteries

Dispose of waste power batteries in accordance with local legal requirements.

Parts

When purchasing accessories, ensure to acquire genuine parts from legitimate channels. We cannot guarantee the quality, safety, and compatibility of aftermarket accessories. Improper accessory purchases may lead to abnormal vehicle operation, causing damage and personal injury. For any inquiries, please contact your local distributor.

TECHNICAL PARAMETER			
Item			QK4840GA
尺寸	L*W*H	mm	2435*897*1875
	Wheelbase	mm	1127~1427
	Front track	mm	730
	Rear track	mm	730
	Min Ground clearance	mm	130
curb weight		kg	120
Max Wheel mass		kg	400
Front wheel toe-in		mm	
Max speed		km/h	20
Climbing gradient		°	15°
Driving type			Rear-engine Rear-drive
Tire	front		16×7.5_14
	Rear		16×7.5_14
Break type	front		-
	Rear		Disc
Suspension type	front		Double wishbone independent suspension
	Rear		Integrated bridge
Steering Type			-

Vehicle nameplate



Vehicle Identification Number (VIN)

The Vehicle Identification Number (VIN) is required when you need parts, service center help, or when registering your golf cart. The nameplate (1) is located on the side of the right main beam of the front frame.